

MERRICK & DAY

CORDED ROMAN BLIND KITS

There are several ways to make a Roman blind, using some or all of the components in the kit. For example the rod pockets can either be made using the tape included in the kit or by sewing tucks in the lining fabric. The instructions here are for an unlined blind and a lined blind using the rod pocket tape. Adapt these make-up methods to suit your own needs.

To adjust the length of the track

1 Work on the opposite end of the track to the cord lock and take off the end cap. Loosen the screw in the cord guide and slide it along the track.

2 Cut the track to the required size with a hacksaw, brush away any metal dust and fit the protective end-caps at each end.

3 Re-position the cord guides 10-15cm (4-6in) in from each end and thereafter spaced equidistance apart and tighten the screws

4 Space the wall brackets evenly across the track and mark their fixing positions on the wall. The universal brackets can be face-fixed outside the window reveal or top-fixed inside the window reveal.

5 To release the brackets from the track, squeeze the plastic lever on the underside of the bracket. Drill, plug and screw the brackets into position and clip the track into place.

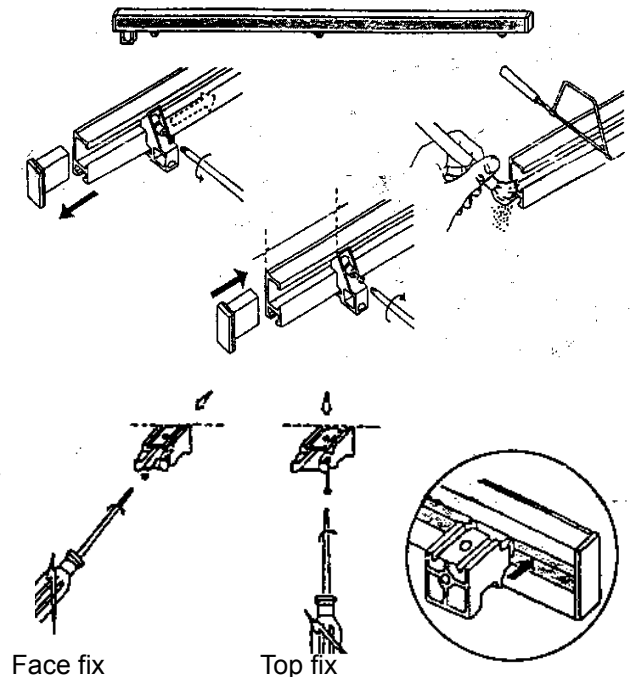

Roman blind standard pleat calculations

Standard pleating is where the folds lie on top of each other. This calculation

Establish the finished length of the blind.

From the finished length of the blind deduct an allowance for the track and cord lock of 6cm.

Divide the remaining figure by an **odd** number to find the size of the pleat sections, which should be approximately between 10-20cm (4-8in).

E.g. finished blind length 86cm – 6cm = 80cm to pleat

80cm ÷ 5 pleat sections = 16cm folds

The rods fall between sections 2 & 3 and 4 & 5 and the folds on the front of the blind fall between 1 & 2 and 3 & 4.

The alternative to 5 pleat sections is either 3 larger sections with 1 rod pocket or 7 smaller sections with 3 rod pockets.

6cm track and cord lock allowance	
1	16cm pleat section
	<i>Fold line</i>
2	16cm pleat section
	<i>Rod pocket tape line</i>
3	16cm pleat section
	<i>Fold line</i>
4	16cm pleat section
	<i>Rod pocket tape line</i>
5	16cm pleat section

To make an un-lined Roman blind

1 Establish the finished size of the blind.

2 Cut the fabric the finished measurements of the blind adding 8cm to each side, to the top and to the bottom for turning allowances. If using a patterned fabric centralise a motif in the middle of the blind also placing a suitable pattern at the top and base of the blind.

3 On the right side of the fabric mark with pins the 8cm side and 8cm bottom turning allowances. Place a pin in each corner points.

4 Lay the fabric onto the table with the wrong side uppermost. Turn in the sides and hem 4cm and then a further 4cm and pin in place.

Turn each corner up 45 degrees so that the fold runs through the corner pin. Turn up the first 4cm and then the second 4cm to make the mitred corners and pin in place. Trim away the excess fabric in the corner of the mitre.

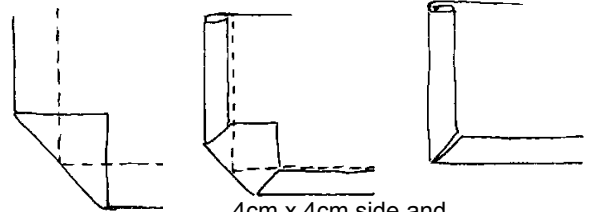

5 Machine or hand-sew along the sides and lower edge turnings. Leave the mitres open to insert the flat aluminium bar later.

6 Calculate the rod pocket tape positions (see page 1). Mark the horizontal lines of the tape positions on the wrong side of the blind with either a row of pins or a chalk pencil.

7 Cut the tapes the width of the blind, in the same place to ensure they line up vertically. Place the tapes onto the marked lines with the open slits for the fibreglass rods facing the top of the blind. Turn the ends of the tape in 2cm to close and neaten, and machine in place on the lower edge of the tape. Hand-sew the ends of the tape to neaten.

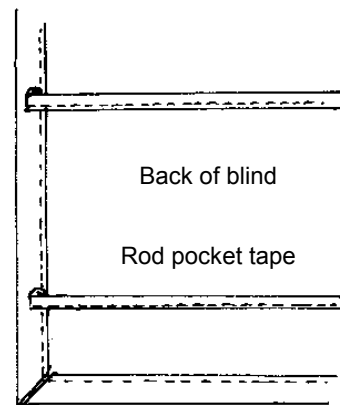

8 Working on the right side of the blind measure the finished length up from the hem and mark with a row of pins. Fold the fabric over along the pin line. Machine the loop tape onto the back of the blind along the top edge only. Trim away the excess fabric to within the depth loop tape. Machine the lower edge and the ends of the tape.

9 Cut the required number of fibreglass rods to the length of the sewn rod pocket tape less 1cm. Wear protective gloves as fibreglass splinters, wrap tape around the cutting area and then cut with a hack-saw. Fit the protective plastic end caps. Slip the rods into the rod pocket tape through the slits at the top of the tape.

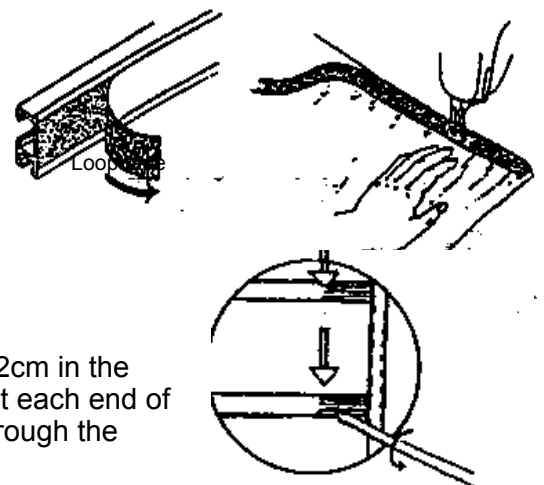

10 Cut the flat aluminium bar to the width of the blind less 2cm in the same way as the fibreglass rods. Fit the plastic end caps at each end of the bar to prevent snagging the blind fabric. Slip the bar through the mitres at hem of the blind and hand-stitch to enclose.

To make a lined Roman blind

1 Establish the finished size of the blind.

2 Cut the fabric the finished measurements of the blind adding 5cm to each side, to the top and to the bottom for turning allowances. If using a patterned fabric centralize a motif in the middle of the blind also placing a suitable pattern at the top and base of the blind.

3 On the right side of the fabric mark with pins the 5cm side and 5cm bottom turning allowances. Place a pin in each corner point.

4 Lay the fabric onto the table with the wrong side uppermost. Turn in the sides and hem 5cm and pin in place.

Turn each corner up 45 degrees so that the fold runs through the corner pin. Turn up 5cm to make the mitred corners and pin in place. Trim away the excess fabric in the corner of the mitre.

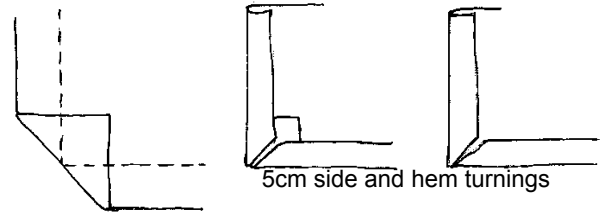
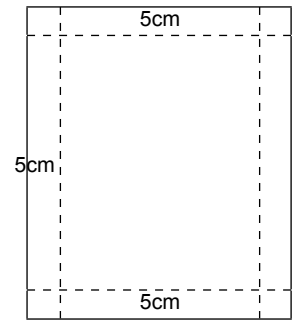

5 Cut out the lining to the finished width of the blind and add 5cm to the length of the blind. Fold and press in 2.5cm down the sides and 2.5cm along the lower edge of the lining. Temporarily pin the lining into position on the back of the blind 2.5cm in from each side and 2.5cm up from the hem fold.

6 Calculate the rod pocket tape positions (see page 1). Mark the horizontal lines of the tape positions on the lining with either a row of pins or a chalk pencil. Remove the lining from the blind fabric.

7 Cut the tapes the width of the blind, in the same place to ensure they line up vertically. Place the tapes onto the marked lines with the open slits for the fibreglass rods facing the top of the blind. Turn the ends of the tape in 2cm to close and neaten, and machine in place on the lower edge of the tape. Hand-sew the ends of the tape to neaten.

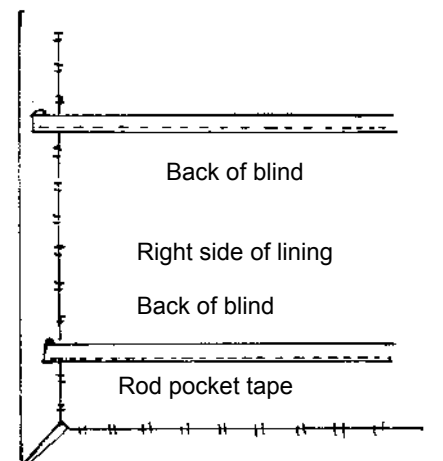

8 Re-position the lining onto the back of the blind 2.5cm in from the sides and up 2.5cm up from the hem fold. Slip stitch down each side and along the hem taking care not to stitch through to the front of the blind.

To hold the fabric and lining together sew small 'spot tack' stitches through the fabrics just below the rod pocket tape wherever the cords will be positioned. These will be barely visible from the right side of the blind and less obtrusive than rows of machine stitching.

Continue steps 8-11 as for an unlined blind.

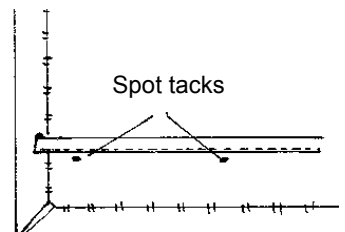

Professional tip when fitting blinds outside the window reveal.

Increase the finished length of the blind above the loop tape by a further 4 cm to make a 'lid' to sit on top of the fixing brackets to close the gap to the wall. (When sewing the loop tape, machine along the top edge only. Hand-sew the lower edge to avoid seeing a second machine line.)

To hold the 'lid' in place on top of the track, sew the loop tape 4cm down from the top edge to adhere to the track. Fix small squares of the self-adhesive tape to the top of the brackets and sew the loop tape to the lid (both tapes supplied in the kit) The 'lid' can be further supported by inserting a spare fibreglass rod.

To fit the blind to the track

1 Adjust the length of the track and fit the brackets to the wall or ceiling as described on page 1.

2 Now fit the blind to the track before fitting onto the brackets. Press the loop tape on the blind to the hook tape on the track.

3 Attach the small plastic 's' hooks to the clear plastic rings and then to the small slits in the rod-pocket tape in line with the cord guides. Thread the cords through the rings.

Alternatively thread the cord directly through the slits in the rod pocket tape omitting the rings and 's' hooks.

4 Fit the locking device onto the lowest rod pocket tape. With the hook uppermost, facing the tape, pull the hook down through the small slit in the tape and turn the locking device to the top of the tape. Trap the cords through the locking device. Trim the ends of the cords to within 10cm to allow for adjustment.

5 Ensure all the cords are equally tensioned and with the blind down flat, tie the cords together and trim the ends 15cm below the cord lock. Open the plastic cord joiner and insert into one half and adjust the length of the single cord with the cord weight.

6 Clip the blind onto the brackets. It may be necessary to adjust the cord tensions using the locking device at the bottom of the blind.

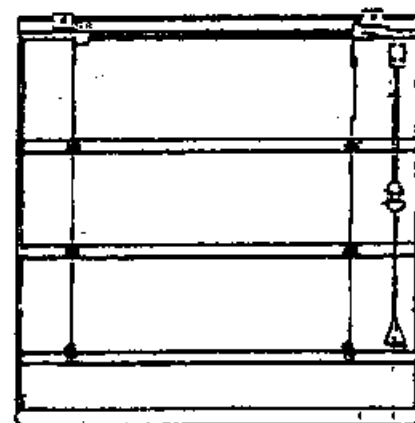
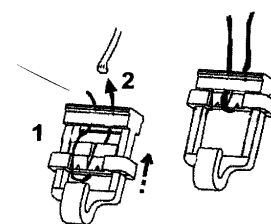
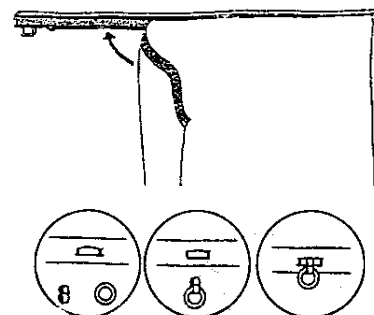

To change the cord lock to a left-hand operation

The track is corded to the right-hand side as standard. To move the cord lock, loosen the cords from the cord lock (1) and pull the cords out of the small guides but leave in the cord lock (2). Take off the track end cap (3), loosen the screw of the cord lock and slide off (4).

Insert the cord lock into the other end of the track (5) and replace the end cap (6). Tighten the cord lock screw (7). Re-thread the cords through the cord guides (8).

